

LAMP®

AZ-GD232-HL STAINLESS STEEL SOFT CLOSING FLAP LID SYSTEM FOR INCLINED SURFACE Installation instructions

Thank you for selecting our product. Before starting installation, please read this manual thoroughly to ensure correct installation. Please keep this manual at hand for future reference.

ABOUT THE PRODUCT

- Damper allows silent closing of lid.
- Suitable for vertical surfaces to surfaces inclined up to 45 degrees.
- Side plates for anti-pinch function.

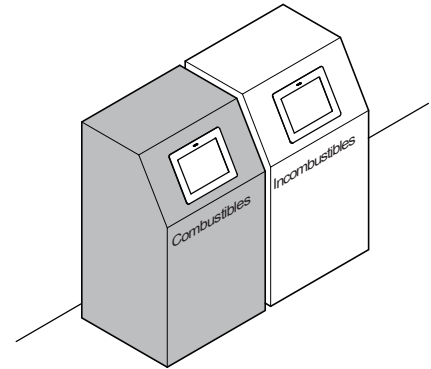

FOR YOUR SAFETY AND CORRECT INSTALLATION

Meaning of symbols

	Warning Caution		Prohibited		Required
--	------------------------	--	-------------------	--	-----------------

Caution If not followed, injury or damage may result.

- ❗ Make sure to fix the balance weight to the position of corresponding angle of mounting surface. If the place is improper, it may affect the movement of lid, and cause injury.
- ❗ To prevent the risk of the product falling and causing injury, ensure that the AZ-GD232-HL is securely fastened to a structure with adequate strength.
- ❗ Do not disassemble nor modify any parts other than those described in this document.
- ⚠ Recommended ambient temperature range is 0 to 40 degrees centigrade.
- ❗ The closing speed of the lid may vary according to ambient temperature. If the product is stored below zero degrees, please store in room temperature for several hours before use.

PARTS DESCRIPTION

Description	Quantity
Flap lid body	1
Warning sticker	1
Cover cap	4

TOOLS NEEDED FOR INSTALLATION

- Screws (not provided)
Choose the suitable length according to the material to be mounted.
Recommended screw : 3mm tapping screw 4 pcs

DIMENSION DRAWING

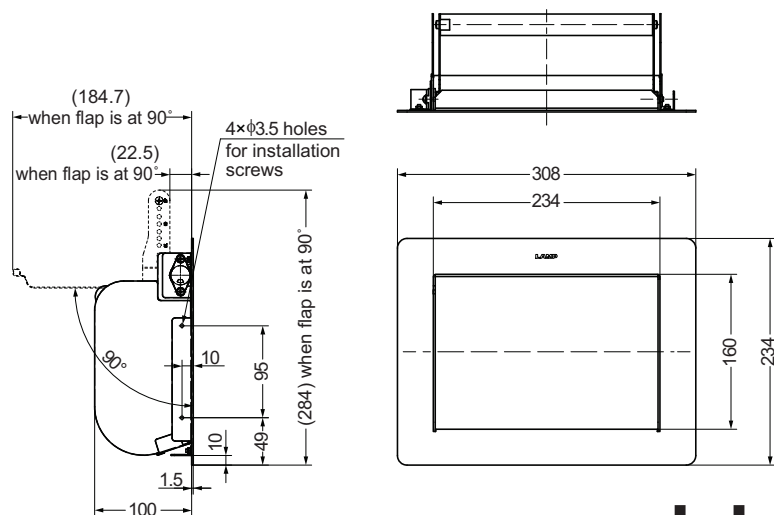

CUTOUT DIMENSIONS

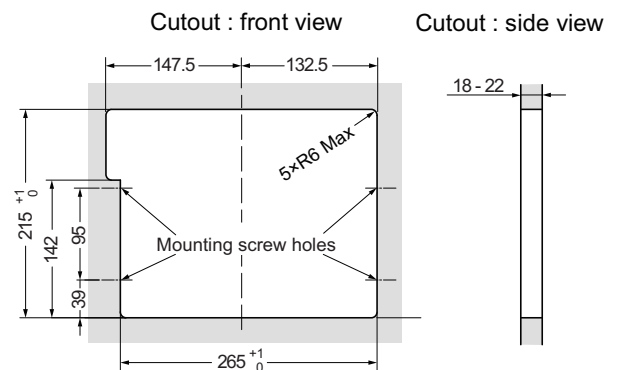

INSTALLATION PROCEDURE

1

Make sure that the LAMP logo is at the top.

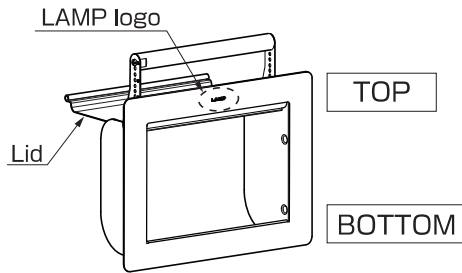

2

Position the balance weight according to the angle of mounting surface. (The factory setting is 45 degree.)

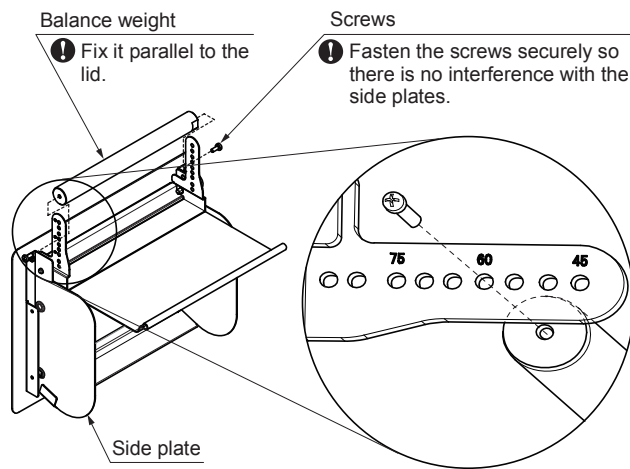

- [1] Unscrew the balance weight and re-fix it to the place which corresponds to the angle of mounting surface.
- [2] If the lid closes too fast or does not close fully, re-position the balance weight.

3

Do not leave any gap between the flap lid body and the mounting surface.

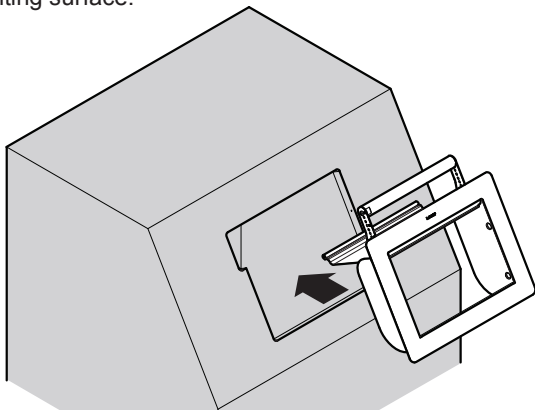

4

- [1] Having opened the lid, insert the screws through the provided access holes (two on each side) and fasten the flap lid body securely.
- [2] Make sure that the final assembly is securely fastened.

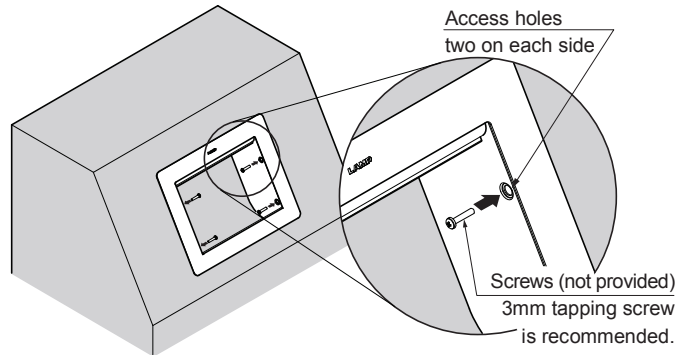

5

Slowly open and close the lid completely a few times in order to ensure correct operation.

6

Cover the access holes with the cover caps provided.

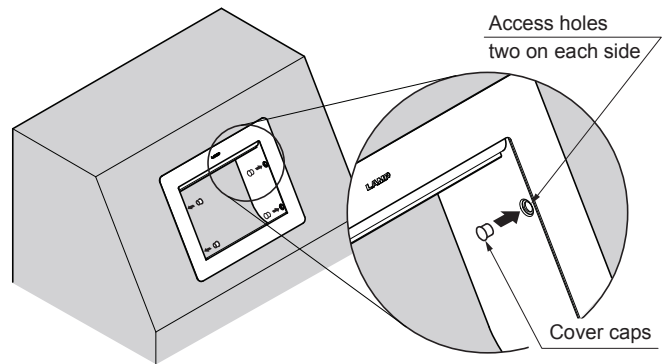

7

Paste the warning sticker in a visible position to avoid any injury when operating the lid.



SUGATSUNE KOGYO CO.,LTD
 Tokyo, JAPAN
 Phone: +81 (0)3 3866 2260 E-mail:export@sugatsune.co.jp

SUGATSUNE KOGYO (UK) LTD
 Reading, UK
 Phone: +44 118 9272 955 E-mail:sales@sugatsune.co.uk

SUGATSUNE SHANGHAI Co., LTD
 Shanghai, CHINA
 Phone: +86 21 3632 1858 E-mail:lamp@sugatsune.com.cn

Guangzhou, CHINA
 Phone: +86 20 6639 3552 E-mail:lamp@sugatsune.com.cn

SUGATSUNE AMERICA, INC
 California, USA
 Phone: +1 310 329 6373 E-mail:sales@sugatsune.com

Illinois, USA
 Phone: +1 630 317 7072 E-mail:sales@sugatsune.com

2 SUGATSUNE EUROPE GmbH
 Düsseldorf, GERMANY
 Phone: +49 211 53812900 E-mail:sales@sugatsune.eu
 ISO9001(Japan Offices and Sugatsune America) and ISO14001(Chiba Production division and Logistics center), certified.

SUGATSUNE KOGYO INDIA PRIVATE LIMITED
 Mumbai, INDIA
 Phone: +91 22 28314490/91 E-mail:sales@sugatsune.in

SUGATSUNE CANADA, INC.
 Phone: +1 514 312 5267 E-mail:support@sugatsune.ca